

POWER FROM SMITH GENERATOR

POWER FROM SMITH GENERATOR SMITH GENERATOR

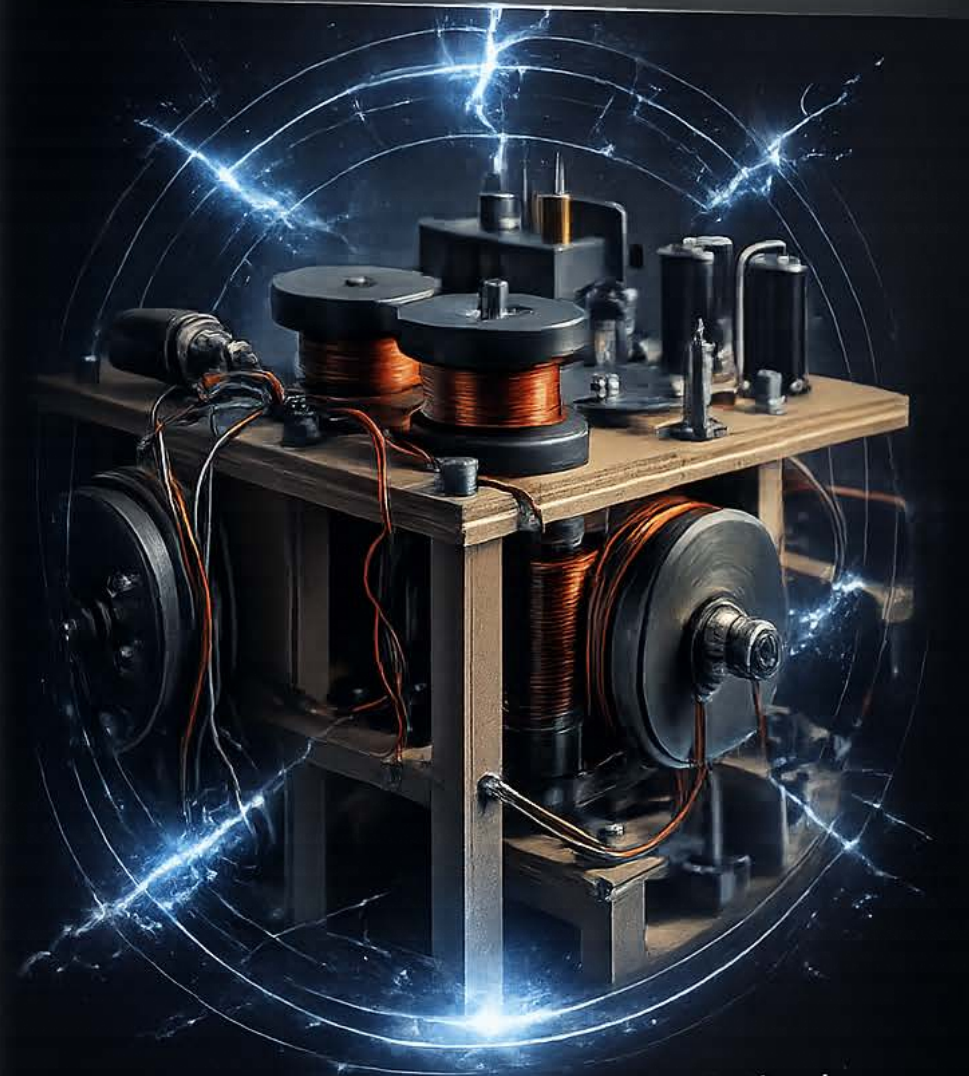

Advanced Energy Extraction Method

Bonus Guide For
Power Grid Generator

Table of Contents

| | |
|--|-----------|
| Introduction | 2 |
| 1. How to Reduce Energy Consumption | 3 |
| Stand By Energy Consumption Charts: | 5 |
| 2. How Does Grid Systems Work | 7 |
| Portable Power Source System | 7 |
| Grid-Intertied Power Source System | 7 |
| Grid-intertied solar power system with battery backup | 7 |
| Off Grid Power System | 8 |
| The Units of the System | 8 |
| 3. From Where to Get the Materials | 11 |
| 4. Equipment | 16 |
| 5. How the Generator Functions | 17 |
| 6. Construction | 26 |
| 7. Gallery | 29 |
| 8.Disclaimer..... | 35 |

Introduction

Since the world is gradually slipping into a energy crisis, it is of utmost importance for us to reduce our dependency on the sources of energy which are nonrenewable.

Clean Renewable sources of energy are those sources which are recurring meaning when you produce energy you don't exhaust any resources. Several examples of renewable energy are solar energy, hydro or water energy, and wind energy.

These sources of energy are freely available in our environment, and are often overlooked and unused. We need to take advantage of these sources of energy, thus we will make a step towards energy independence.

Solar energy i.e the Energy from the sun is the most abundant energy available on our planet. We should take advantage of this energy. By implementing a system which uses the solar energy to power our homes, we will reduce our power bills significantly and also contribute to a greener planet.

Water or Hydro Energy is an fairly effective source of clean renewable energy, and it is mostly produced on a large scale, meaning a lot of investment and time is put into building systems which will produce energy from water. The downside of hydro energy sources is that it is

implausible for an average person to implement it in his home.

Wind Energy Sources have existed for more than 2000 years, they have been used for tasks such as pumping water in the past, as the world has been industrialized, wind has become a common source for generating energy. Wind Turbines can be easily made and implemented even in individual residences, and can help relieve the power bill, by powering the more conventional power sources.

In this book you will learn how to construct another alternative source of energy, which has not reached the mainstream media yet. But with time this energy will be widely accepted and used.

1.How to Reduce Energy Consumption

Even right now without a generator, solar panel, or wind turbine you can conserve energy. Before you start using renewable energy here we present some tips that will help you conserve energy now, and produce more in the future.

- Change your regular light bulb with LED light bulbs (Light-emitting diode bulb - *figure 1*). LED light bulb is 12 times as energy efficient as a tungsten bulb, and lasts for 100,000 hours. Also if you cannot find in your area LED light bulbs, you can use fluorescent light bulbs

which are also more efficient compared to the regular light bulbs. Also don't forget to turn off the light when it's not needed.

- When you turn off your TV, PC, or DVD, it still consumes energy. The standby mode does not mean it doesn't consume energy, as how much energy each appliance uses during standby mode, take look at the chart below. In order to eliminate the energy consumption you could either unplug the appliance or use a switchable power strip for clusters of computer or video products. That way you can switch everything to zero with one action.

The magnitude of the standby power consumption should be taken very seriously, since it comprises from 10% to 15% of your power bill. Altogether, standby power use is roughly responsible for 1% of global CO₂ emissions.

- Use your AC responsibly, the colder you want the inside to be the more energy you use, it's same when you want to use it for heating. Keep it at a comfortable level and don't overuse it. This way you will save at least 1,5Kw per hour if you have 3Kw AC. If the AC is used regularly in your home, it most likely comprises big chunk of your energy bill.

Also make sure the windows and doors in your home are well sealed so no cold or warm air escapes or enters.

- Our last advice is that you air dry cloths as much as you can, since the dryer is “energy vampire”, also use the dish and cloth washer once is fully loaded, this way you save energy and water.

Stand By Energy Consumption Charts:

You should start implementing the advices we presented concerning the reduction of the consumption of energy, since there is no point of using renewable energy when your consumption is the same. This way if you produce 50% of the energy you use, you can eliminate the other 50% with the advices above and you can even start thinking about producing energy and get the power company to pay you instead of the other way around.

Besides the economical benefits of the said advice, don't forget that you are saving the environment also. The steps are easy to follow. Change the regular light bulbs with LED or Fluorescent light bulbs will lower the energy consumed for light as much as 12 times. Using the heating thermostat responsibly will save you as much as 50% of the energy spent on heating, and the same goes for the AC. Using the dish/cloth washer and dryer as advice will drastically lower you energy consumption. Finally eliminating the stand by energy consumption will reduce

your power bill by at least 10%. Start saving now, even before you implement independent energy source, you can slash your power bill by as much as 50%.

2. How Does Grid Systems Work

The following systems represent how you connect the external power supply to your house or grid. In the diagrams we are referring to the energy source a bit vaguely because the same system that is presented could be used for variety of power sources. By power sources we mean Solar Panels, Wind Turbines, and Energy Generators.

Portable Power Source System

1. Power Source
2. Charge Controller
3. Battery
4. Inverter
5. Household

Grid-Intertied Power Source System

1. Power Source
2. Array DC disconnect
3. Inverter
4. AC Breaker panel
5. Household
6. Kilowatt per hour meter
1. 7. Grid

Grid-intertied solar power system with battery backup

1. Power Source
2. Array DC disconnect
3. Charge Controller
4. Deep cycle battery
5. System meter

2. 6. Main DC disconnect
3. 7. Inverter
4. 8. AC Breaker panel
5. 9. Kilowatt per hour meter
6. 10. Grid
7. 11. Household

Off Grid Power System

1. Power Source
2. Array DC disconnect
3. Charge Controller
4. Deep cycle battery
5. System meter
1. 6. Main DC disconnect
2. 7. Inverter
3. 8. Generator
4. 9. AC Breaker panel
5. 10. Household

The Units of the System

Array DC Disconnect:

DC Disconnect is used in the system, so you can shut off the system much safer and easier. The reason for shutting off the system would be mainly maintenance.

Deep Cycle Battery:

This is the battery you will use in your system once you build the full scale generator. If you cannot afford a brand

new battery, you can get on the cheap from old golf cart or forklift.

Main DC Disconnect:

The main DC disconnect is used for disconnecting the Inverter for maintenance or emergency situations.

Inverter:

The Inverter is used to invert the direct current or DC into alternating current or AC. This conversion is need since most appliances in the house use AC.

Gas Powered Generator:

If you are implementing complete off grid system, you should have Gas Powered Generator. There might be situation when you want to shut down your system for maintenance, during those situations you will use this generator.

AC Breaker Panel:

The AC Breaker panel is where all the electrical wiring is connected with your power provider. This panel is usually found in a utility room, garage, or outside the building.

Be aware each state and country has different standards for connecting alternative energy source to the AC panel. Also in most countries it is illegal to open this box by yourself, unless you are qualified electrician.

We recommend that you contact your power supply company concerning this issue and do not take matters in to your own hands before you do that.

If you do not want to connect your system to the breaker panel, you can run appliances just from the inverter which is much easier and cheaper option.

Grid:

The main power line that comes to your house that comes from the power company is called Grid. The term Off Grid refers that you are energy independent from the power supply company.

Household:

When we referred in the previous diagrams to the household, we meant the household loads. This consists of everything that is connected to the breaker panel.

3. From Where to Get the Materials

If you are based in *UK* or *Europe* we the following web sites:

Lead Acid Batteries:

<http://shop.eurobatteries.com>

Components:

<http://www.maplin.co.uk/>

<http://www.radioshack.com/>

Magnets:

<http://e-magnetsuk.com/>

If you are based in *USA* or *Canada* we recommend the following web sites:

Components:

<http://www.allelectronics.com/>

<http://www.radioshack.com/>

Magnets:

<http://www.magnets4less.com/>

Parts List:

1. For the Start up Input current you will need either a 12V car battery.

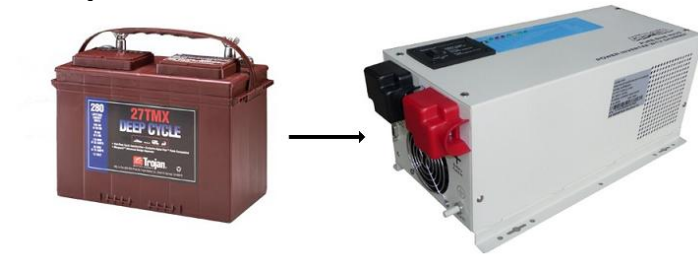

2. 6*High Voltage Diodes (HVP16 HV Diode 16kV 750ma)



3. 1* Inverter 12V to 220V-240V 1A 50/60Hz



4. Neon Tube Driver or Neon HV Converter (Input 220V Output 8kV/30mA)



5. 1*.2uF 4000V Capacitor (or you can stack two 2000V capacitors together)

6. Spark Gap (You will need to construct one From two copper rivets 4mm diam.) or you can buy spark arrestor or enclosed spark gap.

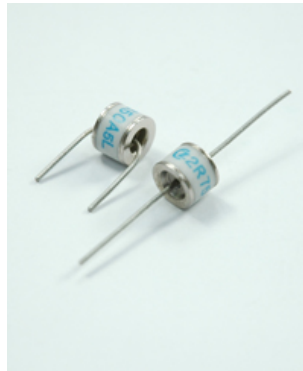

7. For the Coils you will need 18 m of 1.12 mm diam. standard copper wire (2.54mm diam. with insulation), inductance 80uH;
2*2m 2.18mm solid copper wire, inductance 8, 16, 19uH.



8. 1*.47uF High Voltage Capacitor



9. Capacitor Bank : 8000V 2uF



10. High Voltage Resistor 1Kohm



11. Inverter 12V to 120V , 300 to 7500W or more 60Hz OUTPUT.

4. Equipment

Multimeter:

Digital multimeter is ok but we highly recommended to use an Analogue Amp Meter, which goes up to 1amp or more. You will also need the meter to measure your input amps as well your battery voltages.

Soldering Iron:

Soldering iron will be used to solder the circuit. The circuit will still operate if the connections aren't soldered, though once you are sure it is wired correctly, you should solder all the connections.

5. How the Generator Functions



The battery supplies a small current through a protecting diode, to a standard off-the-shelf "true sine-wave" inverter.

An inverter is a device which produces mains-voltage Alternating Current from a DC battery. He feeds the output from the inverter into a variable transformer called a "Variac" although this is often made as part of the neon-driver circuit to allow the brightness of the neon tube to be adjusted by the user. This arrangement produces an AC

output voltage which is adjustable from zero volts up to the full mains voltage (or a little higher). The use of this kind of adjustment usually makes it essential for the inverter to be a true sine-wave type. As the power requirement of the neon-tube driver circuit is so low, the inverter should not cost very much.

The neon-tube driver circuit is a standard off-the-shelf device used to drive neon tube displays for commercial establishments. The one used contains an oscillator and a step-up transformer, which together produce an Alternating Current of 9,000 volts at a frequency of 35,100 Hz (sometimes written as 35.1 kHz). The term "Hz" stands for "cycles per second". It lowers the 9,000 volts as he gets great power output at lower input voltages and the cost of the output capacitors is a significant factor. The particular neon-tube driver circuit which is used here, has two separate outputs out of phase with each other, so it is connected together and uses a blocking diode in each line to prevent either of them affecting the other one. Not easily seen in the photograph, the high-voltage output line has a very small, encapsulated, Gas-Discharge Tube spark gap in it and the line is also earthed. The device looks like above.

Please note that when an earth connection is mentioned, we are talking about an actual wire connection to a metal object physically buried in the ground, whether it is a long

copper rod driven into the ground, or an old car radiator buried in a hole.

The output of the neon-tube driver circuit is used to drive the primary "L1" winding of a Tesla Coil style transformer. This looks ever so simple and straightforward, but there are some subtle details which need to be considered.

The operating frequency of 35.1 kHz is set and maintained by the neon-tube driver circuitry, and so, in theory, we do not have to do any direct tuning ourselves. However, we want the resonant frequency of the L1 coil and the capacitor across it to match the neon-driver circuit frequency. The frequency of the "L1" coil winding will induce exactly the same frequency in the "L2" secondary winding.

However, we need to pay special attention to the ratio of the wire lengths of the two coil windings as we want these two windings to resonate together. A rule of thumb followed by most Tesla Coil builders is to have the same weight of copper in the L1 and L2 coils, which means that the wire of the L1 coil is usually much thicker than the wire of the L2 coil. If the L1 coil is to be one quarter of the length of the L2 coil, then we would expect the cross-sectional area of the L1 coil to be four times that of the wire of the L2 coil and so the wire should have twice the diameter (as the area is proportional to the square of the radius, and the square of two is four).

The device uses a white plastic tube as the former for his "L1" primary coil winding. As you can see in the picture, the wire is fed into the former, leaving sufficient clearance to allow the former to slide all the way into the outer coil. The wire is fed up inside the pipe and out through another hole to allow the coil turns to be made on the outside of the pipe.

The key point here is that the length of wire in the "L1" coil turns should be exactly one quarter of the length of wire in the "L2" coil turns. The "L2" coil used here is a commercial 3-inch diameter unit from Barker & Williamson, constructed from uninsulated, solid, single-strand "tinned" copper wire (how to make home-build versions is shown later on). We have taken this coil and unwound four turns in the middle of the coil in order to make a centre-tap. Then measured the exact length of wire in the remaining section and made the length of the "L1" coil turns to be exactly one quarter of that length. The wire used for the "L1" coil is a very flexible wire with a very large number of extremely fine uninsulated copper wires inside it.

The sliding action allows the primary coil "L1" to be positioned at any point along the length of the "L2" secondary coil, and that has a marked tuning effect on the operation of the system.

The outer "L2" coil does not have any kind of tube support but instead, the coil shape is maintained by the stiffness of the solid wire plus four slotted strips. This

style of construction produces the highest possible coil performance at radio frequencies. With a Tesla Coil, it is most unusual to have the L1 coil of smaller diameter than the L2 coil.

The "L2" coil has two separate sections, each of seventeen turns. One point to note is the turns are spaced apart using slotted strips to support the wires and maintain an accurate spacing between adjacent turns. It must be remembered that spacing coil turns apart like this alters the characteristics of the coil, increasing its "capacitance" factor substantially. Every coil has resistance, inductance and capacitance, but the form of the coil construction has a major effect on the ratio of these three characteristics. The coil assembly is held in position on the base board by two off-white plastic cable ties. The nearer half of the coil is effectively connected across the further half as shown in the circuit diagram above.

For example, if the length of the "L2" coil wire is 160 inches and "L1" is to be one quarter of that length, namely, 40 inches. Then, if the "L1" coil has an effective diameter of 2.25 inches, (allowing for the thickness of the wire when wound on a 2-inch diameter former), then the "L1" coil would have 5.65 (or 5 and 2/3) turns which causes the finishing turn of "L2" to be 240 degrees further around the coil former than the start of the first turn - that is, five full turns plus two thirds of the sixth turn.

The L1 / L2 coil arrangement is a Tesla Coil. The positioning of the "L1" coil along the length of the "L2" coil, adjusts the voltage to current ratio produced by the coil. When the "L1" coil is near the middle of the "L2" coil, then the amplified voltage and amplified current are roughly the same. The exact wire ratio of these two coils gives them an almost automatic tuning with each other, and the exact resonance between them can be achieved by the positioning of the "L1" coil along the length of the "L2" coil. While this is a perfectly good way of adjusting the circuit, in the build shown in the photograph, to get the exact tuning connect a capacitor across "L1" as marked as "C" in the circuit diagram.

This capacitor is an optional component. Connect a small capacitor across the "L2" coil, also for fine-tuning of the circuit, and that component is optional and so is not shown on the circuit diagram. As the two halves of the "L2" coil are effectively connected across each other, it is only necessary to have one fine-tuning capacitor.

There are various ways of dealing with the output from the "L2" coil in order to get large amounts of conventional electrical power out of the device. The method shown here uses the four very large capacitors seen in the photograph. These have an 8,000 or 9,000 volt rating and a large capacity and they are used to store the circuit power as DC prior to use in the load equipment. This is achieved by feeding the capacitor bank through a

diode which is rated for both high voltage and high current, as stated that the device produces 8,000 volts at 20 amps, in which case, this rectifying diode has to be able to handle that level of power, both at start-up when the capacitor bank is fully discharged and "L2" is producing 8,000 volts, and when the full load of 20 amps is being drawn.

The actual diodes used happen to be rated at 25 KV but that is a far greater rating than is actually needed.

In passing, it might be remarked that the average home user will not have an electrical requirement of anything remotely like as large as this, seeing that 10 kW is more than most people use on a continuous basis, while 8 KV at 20 A is a power of 160 kilowatts. As the neon-tube driver circuit can put out 9,000 volts and since the L1 / L2 coil system is a step-up transformer, if the voltage fed to the capacitor bank is to be kept down to 8,000 volts, then the Variac adjustment must be used to reduce the voltage fed to the neon-tube driver circuit, in order to lower the voltage fed to the L1 / L2 coil pair, typically, to 3,000 volts.

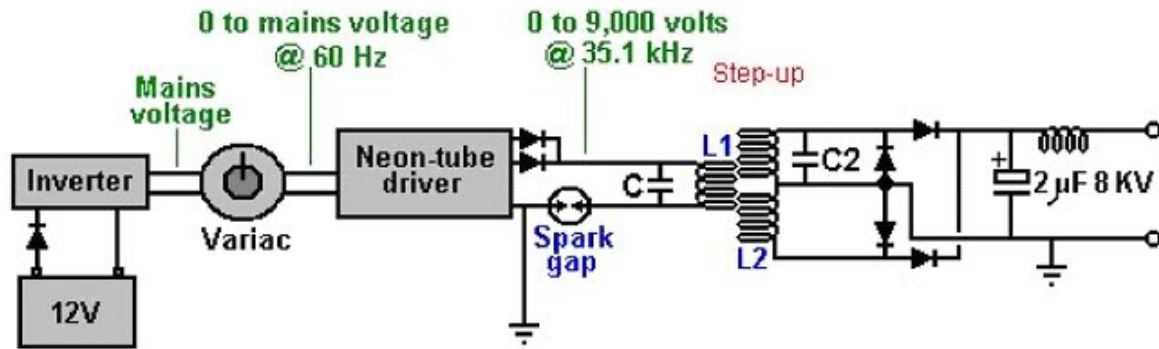

When the circuit is running, the storage capacitor bank behaves like an 8,000 volt battery which never runs down and which can supply 20 amps of current for as long as you want. The circuitry for producing a 220 volt 50 Hz AC output or a 110 volt 60 Hz AC output from the storage capacitors is just standard electronics. In passing, one option for charging the battery is to use the magnetic field caused by drawing mains-frequency current.

The output current flows through the left hand winding on the cylindrical former.

The DC output produced by the four diodes was then used to charge the driving battery, and the power level produced is substantially greater than the minor current drain from the battery. Consequently, it is a sensible precaution to pass this current to the battery via a circuit which prevents the battery voltage rising higher than it should. A simple voltage level sensor can be used to switch off the charging when the battery has reached its

optimum level. Other batteries can also be charged if that is wanted.

Pay attention to the fact that the cables used to connect the output of "L2" to the output of the board, connecting the storage capacitors on the way, are very high-voltage rated cables with special multiple coverings to ensure that the cables will remain sound over an indefinite period. It should be remarked at this point, that the outer 3" diameter coil used, is not wound on a former, but in order to get higher performance at high frequencies, the turns are supported with four separate strips physically attached to the turns.

Please bear in mind that the voltages here and their associated power levels are literally lethal and perfectly capable of killing anyone who handles the device carelessly when it is powered up. When a replication of this device is ready for routine use, it must be encased so that none of the high-voltage connections can be touched by anyone. This is not a suggestion, but it is a mandatory requirement, despite the fact that the components shown in the photographs are laid out in what would be a most dangerous fashion were the circuit to be powered up as it stands. This is a "one hand in the pocket at all times" type of circuit and it needs to be treated with great care and respect at all times, so be sensible.

6. Construction

For the construction you will need to follow the wiring diagram and connect the parts as shown:

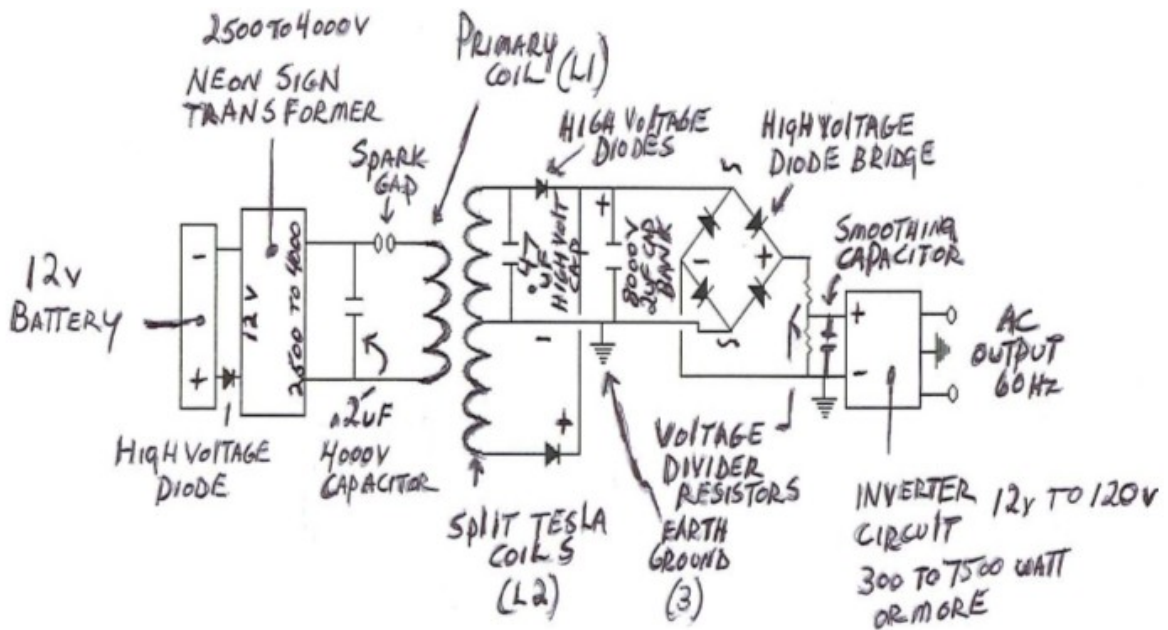
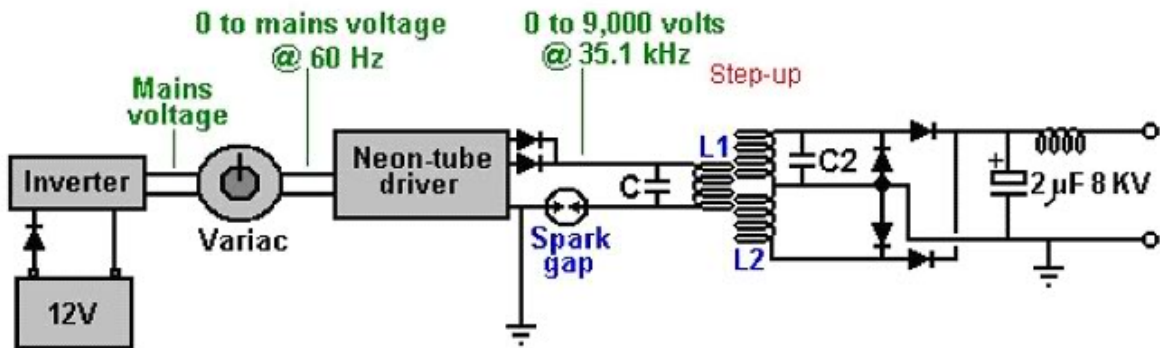

For the coils you will need to wind like so:



If you decide on building yourself a spark gap :

The spark gap is build using the two copper rivets mounted on a ceramic insulated copper shunt or any kind of improvised stand like shown below. (for better performance of the device try different material rivets- like carbon and copper etc.)

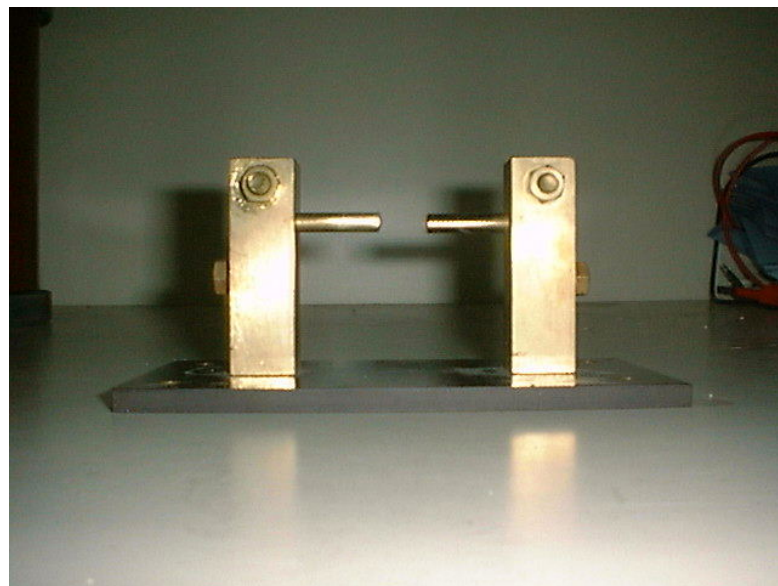

7. Gallery



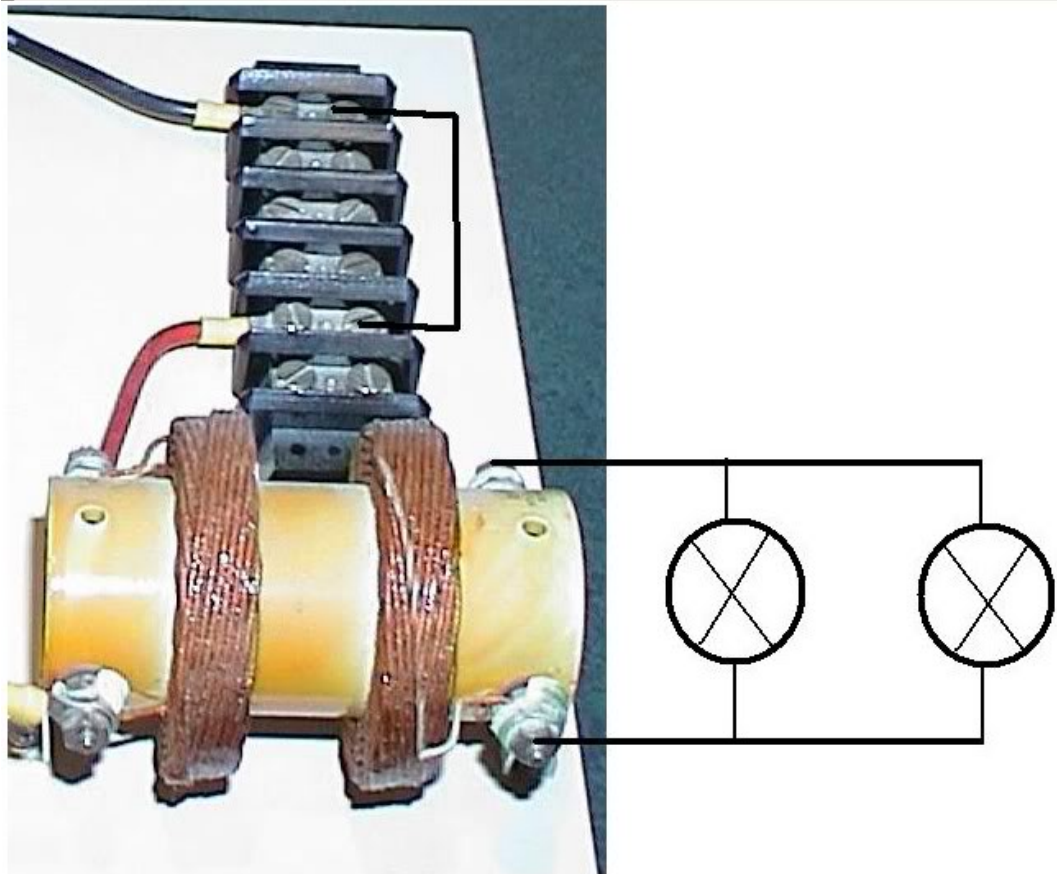

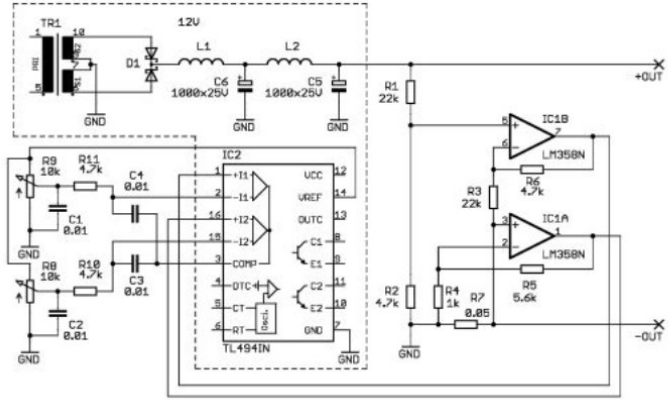

По присланным Mrbasil осциллограммам этот неоник подходит, я сам его не проверял, нет возможности приобрести.







