

POWER GRID GENERATOR

POWER GRID GENERATOR

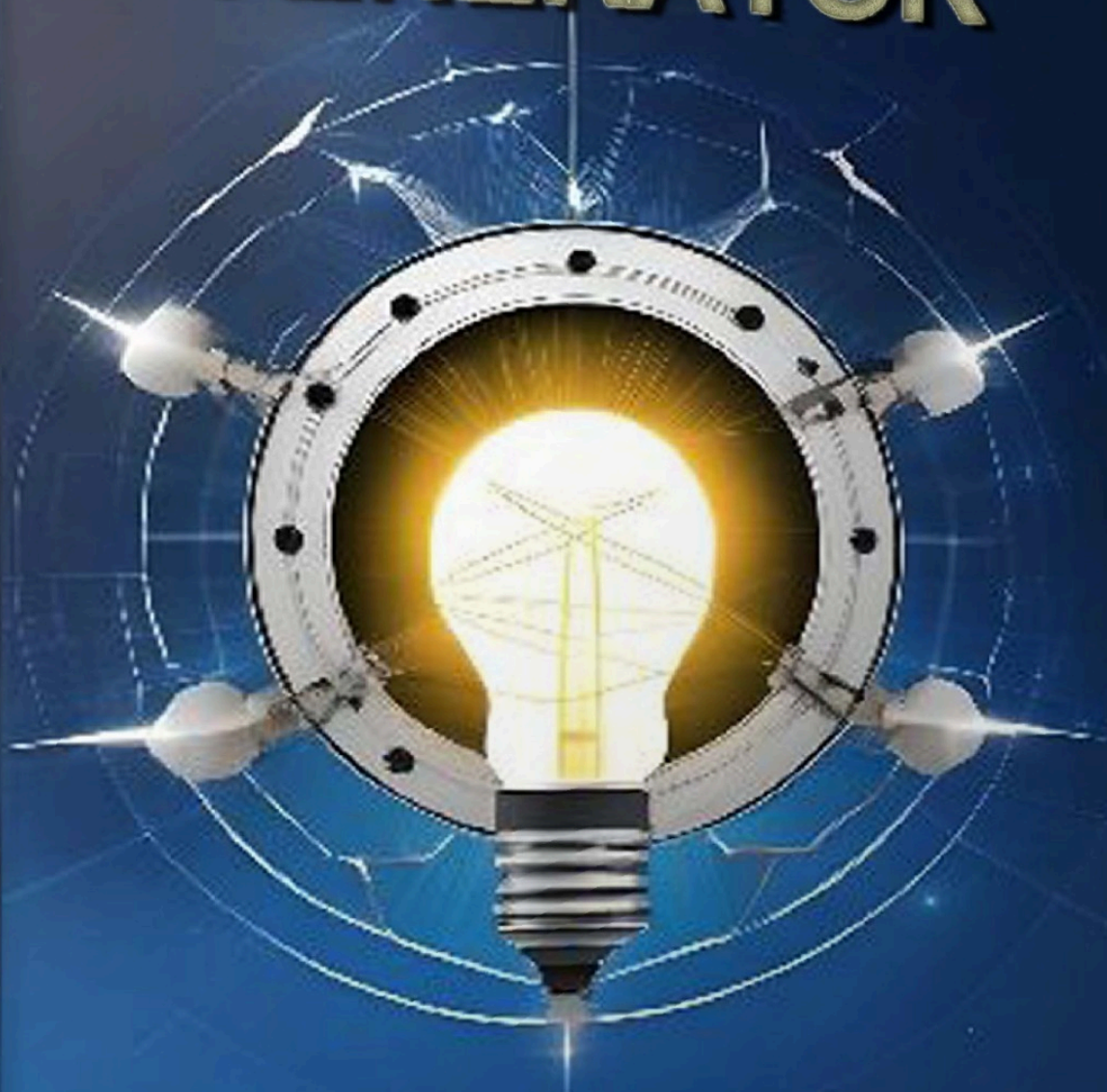

Future of Energy

IN

1. Introduction

1.2 Power Grid Generator – Means of operation

The generator is based on the following principles: the magnetic field generated by a group of controlled and temporized coils can set a rotor in motion and this motion can then be used as source for an alternator.

This generator is based on the revolutionary behaviour of electricity fields. After passing through the first field, a small current is multiplied 6 times... without losing amps or volts ... This phenomenon is called 'Overunity'.

Without going into scientific details furthermore, we offer you a product, as simple as it is effective: a group of diodes generates a magnetic field using a control board.

The magnetic field is transferred to the magnets on a rotor creating rotational motion, which in turn engages an alternator which produces electricity. In short, these are the components of our generator, as units.

Here's a diagram of the generator:

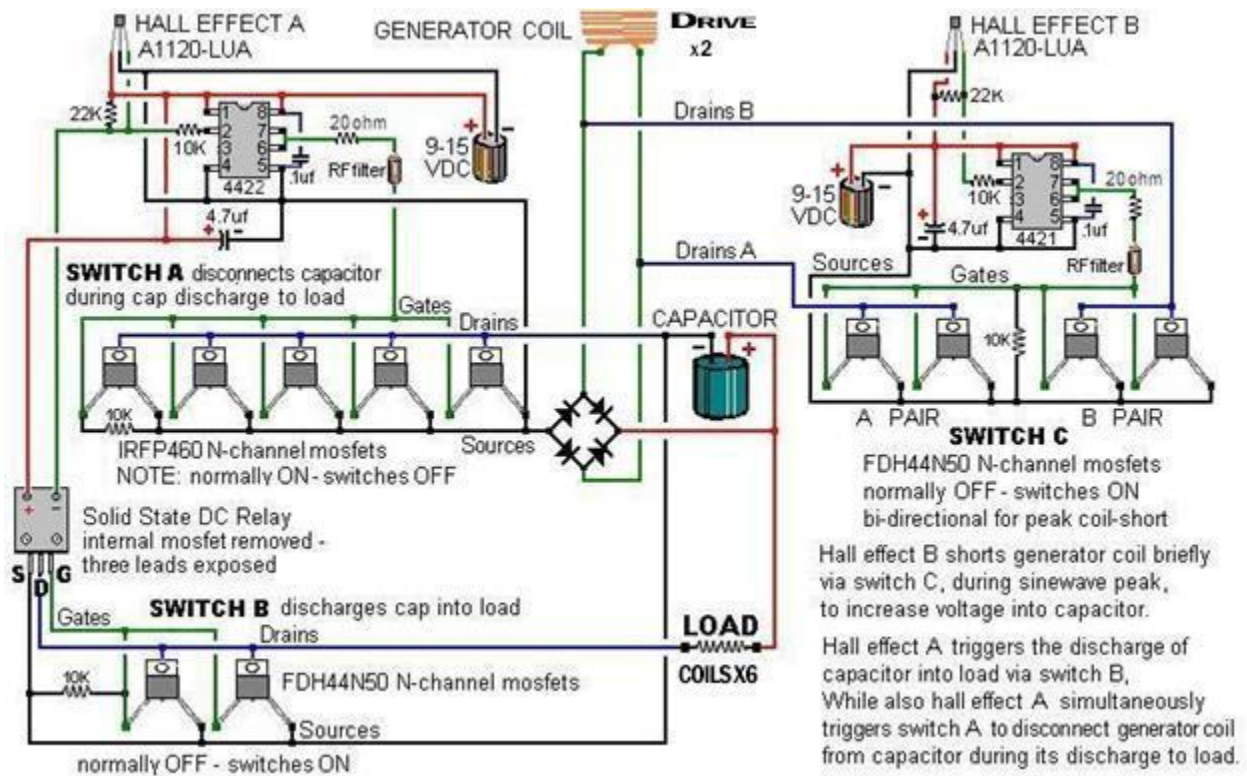

The diagram is only for one drive coil, and we used in the current project two drive coils.

1.3 Applications

Power Grid Generator can be used as a power generator, a portable generator or it can charge a group of batteries (which were discharged for later use).

1.4 Advantages

This generator is constructed of lightweight but solid materials and it requires extremely small circuits in size and cost. It is also the perfect choice for a cleaner and healthier future for our children, since it doesn't involve any smoke or noise.

The low cost, the light weight, no noise and no pollution make this generator a strong competitor for any large scale device currently known.

2. Tools and Materials

2.1 List of tools

a. Fixed isolated screwdrivers set



b. Magnetic head screwdrivers set



c. Wire strip pliers



d. Cutter



e. Scissors



f. Small beaked pliers



g. Normal pliers



h. Drill



i. Drill bits set



j. Adjustable wrench



k. Fixed wrenches



I. Caliper, ruler, protractor

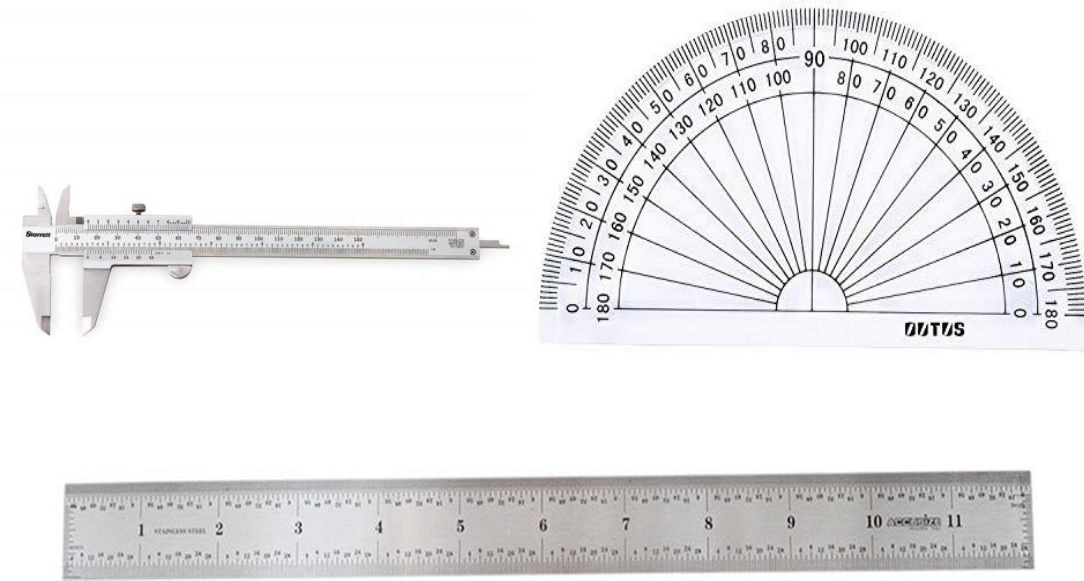

m. Measuring Device



n. Electrical cables of different colors

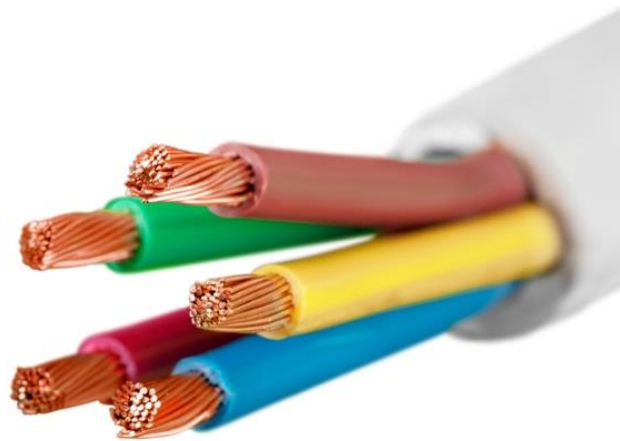

2.2 List of materials

a. Two-component adhesive



b. Insulating Tape



c. Zip Ties



d. Long bolts for fixing 8-10 pcs



e. Short bolts, filed washers



f. A piece of rubber for electrical isolation



g. Marker



h. 500m copper wire for AWG winding



i. Alternator 1 piece



j. Switcher 1 piece



k. Neodymium magnet 12 pcs



l. Axle bearings 12 pcs



m. Hamlin 55140 magnetic sensors 2 pcs



n. Cable lugs



o. Extension cords 8 pcs

p. batteries 12v 1 pcs



q. Control board MMG-041 1 pcs

r. Coils 8 pcs

s. Magnetic core 8 pcs

t. Plexiglass (textolite/wood) cut in different sizes and shapes to sustain various components

- Cylinder - 3 cm thickness 1 pcs (it will be cut in 6 pcs x 5mm)

- 5 x 5 cm frames (used for supporting the coils) - 8 pcs

- Smooth edges - 2 pcs

- Test board - 6 bulbs connected in series, bulb switch, plug, plug switch, cables

Please notice there are no other connections hidden on the other side.

3. Modules

a. Coil Construction

We will start by winding the copper wire on the plastic pad, leaving one end for subsequent couplings. At this point, we will make sure that spires to be positioned next to each other, avoiding blanks.

Tip: To avoid slipping wire, you can fix it with a piece of duct tape.

Make sure the spires are nicely arranged. About 300 spires are needed.

Eventually, the remaining end will be arranged in the opposite edge of the first, for easier tracking during connection.

You can isolate with duct tape and then the loose ends will be stripped using a cutter.

We will attach cables of different colors (in this case, black for the ending point and brown for the starting point), then isolate the connections and position them as shown in the picture for ease of connectivity.

We will then prepare the two-component adhesive that will fix the magnetic core inside the plastic tube on which we have wound the copper wire. It needs about 15 minutes to dry. For efficiency, we have already built the other seven coils using the exact same method.

b. Construction of the rotor

Because we need a support of about 3 cm, we will assemble the six pieces of Plexiglas used in this case, in one single disc to avoid unnecessary friction.

In the present project, we are using Plexiglas for better visibility, for transparency and in the end for less weight.

We will utilize a longer bolt in order to have a fixed support and to subsequently tighten the nut for stiffening and hardening.

For this purpose, we will need the two component adhesive again, to point apply on the surface of the discs. We will enlarge this surface by rotating the discs, as shown in the picture.

Caution: Do not prepare a large amount of adhesive because it is likely to harden and become unusable.

We will repeat the process until we have added all discs.

Caution: Do not over tighten the bolt or you'll crack the Plexiglas (risk disappears if you use a version of textolite or wood with the specified size).

After fastening and drying (around 15 min) of adhesive, we will remove the rotor from support.

Then, using a ruler, we'll draw a diameter as shown in the picture.

Then draw another diameter at 90 degrees. Then, using a protractor, we will halve to 45 degrees the already marked sectors.

Next, we need to fasten the neodymium magnets on the disc we obtained.

Because there have holes, they can be fixed by screwing in wood or textolite. In this case, we will use the two-component adhesive again.

The magnets will be marked north (N) and fixed with the middle on each axis direction.

In the end, the disc will have the magnets mounted as shown in the image. This requires drying time, which is why we recommend you stick them one at a time.

c. The supports for coils

These will be fixed as shown in the picture on each of the pieces cut in a square with the two-component adhesive. It will allow for drying and curing.

Make sure the wires are positioned on one side of the square. The side on which we will stick the plastic brackets will be the one where we left the cables for subsequent connections.

We proceed analogously for all coils.

d. Connectors assembly

They will be mounted above the plastic bracket as shown in the picture. The connection bridges will be placed on the direction of the connectors. Subsequently, the free ends will be introduced in two of the four couplings. The same coupling rule will be followed for easy connectivity later.

We'll do the same for all 8 coils.

4. Mounting Device

a. Rotor assembly

We will use one of the longer bolts as a pin.

Then, we will put one of the bearings and fix it with a bolt. Next, we'll add another bolt (which then we can use for disc adjustment) to create the constraining effect. Then we'll add a washer...disc, a new washer ... bolt ... and fasten the disc between the two bolts. Then add the second bearing and fasten it with a bolt.

The disc must run easily without friction on the two bearings.

b. Bracket support assembly

We will now take a Plexiglas side, drill a central hole in which we'll put the bearing and small side holes that will ensure fixation.

We will use long bolts with washers and nuts as shown in the image. Don't over tighten the bolts, to avoid cracking the material. We will ensure that they are properly tightened to have the best possible overall reinforcement.

Next, we will introduce the rotor shaft mounted above.

Next to each magnet, we will fix the bracket supports so that the distance from the center of the coil to the magnet to be 3 mm. Using the caliper to do the measurements, we will make sure that the distances are correct. In this case, the attachment will be made using the adhesive again. If you use textolite or wood, you can utilize L-sites, screws or other fasteners.

You can also mark the support spot for the coils, so you don't have to repeat the measurements.

The adhesive's purpose is to fix the brackets, hardening being achieved with the other side.

If, when fixing with adhesive, the coils will move, we'll repeat the measurements after each fastening. It is the smoothest part of the assembly that requires skill and patience.

After drying, you'll see the final arrangement of the coils. Our generator is already beginning to come alive.

We now need to add the other side to the assembly. During drying of the adhesive, on fastening the coils, you can see we have placed 4 bolts into the holes near the central axis. This side part will be put down easily, inside the holes, without excessive pressure to prevent damage to the Plexiglas. Analogous to the first, we will fix the fastening bolts using the washer and nut system. A spacer under the top side will leave the rotor shaft free. Now stiffen slightly.

Then we mount the switch and fasten small bolts for the alternator.

c. Mounting the control and recovery board

First, we need to determine the place where our board will be located. Then, we'll mark the spot and drill the proper holes, pressing slightly not to crack the support.

Also make sure the holes do not pierce the coils, so avoid drilling towards the coils. The spacing will be done using bolts.

In this case, we will only need 3 bolts, as it is not required to support heavy weight.

We will use fine-tipped pliers for fixing bolts. So this is how we mount the control board.

d. Coils connection

Two of the eight coils, which are called control coils, will link directly to the control board and the other will be connected in series.

We are using cables of variable length, so that they reach up the control board.

At the end where we have the board, we will use connectivity lugs. The cables are plugged into the connector on the coil, according to the color code, as they represent the extension of the coils' ends: brown to brown, black to black.

Brown wires will come outside the control board at each end of it.

Control coils are connected directly to the board, each on the control board's ends, as shown in the picture.

The coils connected in series will be joined together like this: the remaining pins from the connectors on the coils are joined to each other with wires of the same color.

We'll then repeat the procedure, noting that control coils will be "left out" from the series connection.

The end of this series connection will be linked with lugs on the 3, 4 pins of the control board as shown in the picture.

Care must be taken when pins are connected to the control board, so they do not touch each other. You can use duct tape to prevent this from happening.

Recap: The control coils that you see here will be directly connected to the pins outside the MMG-041 board. The remaining coils are connected in series and the end of the series will also be connected to the control board.

e. Fastening the 55140 Hamlin magnetic sensors

At a distance of about 3 cm from the edge, we will mount the neodymium magnets (which control the magnetic sensors) on the rotor.

General Summary:

So, on one lateral side we placed the coils. Two of them are control coils, connected to the pins outside the control board and the rest are connected in series and to pins 3, 4. On the other side of the plexiglass support we mounted the control board.

After mounting the magnets on the axles, we have also placed on one side of the rotor, the magnets necessary for the magnetic impulse, controlled by the board, on about 3 cm from the edge.

The other plexiglass support contains the switch and the alternator.

The pins made of short bolts are for:

- Powering the 12V battery
- Output of the alternator, where we get the 110V – the right image

f. Generator assembly

It is time for the finishing touch and connection of the assemblies obtained so far.

We will use two batteries as spacers, not to disturb the central axis of the rotor.

First fix the rotor position.

Then cover with the other support, slightly tightening the entire assembly with the bolts.

From the 12V pins of the battery, we connect to the motherboard in pins 6, 7. The positive uses the red color and the negative uses the blue color.

Following is the coupling of magnetic sensors with adhesive. We will check both the distance of the cables that reach the control board, as well as their location from the magnets mounted on the lateral side of the rotor.

When the magnet passes next to the sensor, you will hear a smooth click.

Later, after drying, the sensors will be connected to the control board.

Meanwhile, we can adjust the rotor shaft and couple the alternator to the switch of the device.

We'll show you how they are coupled, previously isolating the ends to avoid short circuits between the pins of the control board. The positive is

represented by the green (with red lug end), and the negative is represented by the black wire (blue lug end).

Therefore we obtained the couplings where we have:

1. Control coils - pins 1, 2 (top-down) and pins 11, 12.
2. Coils in series - pins 3, 4.
3. Magnetic sensor Nr.1 - pins 5, 8.
4. Magnetic sensor No.2 - pins 9, 10.
5. 12v Battery – pins 6, 7.

As we were saying, on the opposite side, we connected the alternator to the switch, and the switch to the 12V power supply as shown in the image.

The last stage of our project is using zip ties for reinforcing and proper fastening of the existing cables. We aim to have the best possible ergonomics of the assembly, so that in the end we can easily distinguish all the building units, connectivity as well as functionality of the generator without any accidental friction.

We will conduct a brief inspection at the pin connection wires.

And here we are and at the end of our project.

We will mount the 12V battery to the pins indicated on the front panel, respecting the positive to positive and negative to negative rule.

Also, the test panel (consisting of 6 bulbs and sockets) will be connected at this stage.

We are working with HIGH VOLTAGE, so make sure:

- The switch is off (in this case, down)
- The wiring connections are properly insulated

Interacting with the 110V must be done with extreme caution, as there is risk of electric shock.

Also avoid touching bolts that connect to 110V, sufficient reason for applying an insulating layer of duct tape.

5. Test

The last connections were the 12V battery to the pins on the front panel and the test panel with 6 bulbs and socket (on which we hooked a measuring device).

Say START. Note that it starts working. After about 5 seconds needed for the rotation speed to stabilize, we can start the test panel for the 6 bulbs. As you can see, they are working properly.

Then you can also power the plug using the switch, to certify those 110V of the plug. Deviation from the 107V display is allowed.

Thank you for joining us.

6. USEFUL SITES FOR COMPONENTS

<http://www.allmagnetics.com/>

<http://www.digikey.com/>

<http://www.keltechplastics.com/index.html>

<http://www.synflex.com/>

<http://www.allelectronics.com/>

<http://www.digikey.com/>

<http://www.newark.com/>

<http://www.mcmaster.com/#>

http://www.radioshack.com/product/index.jsp?productId=2049723&locale=en_US

http://www.radioshack.com/product/index.jsp?productId=2049723&locale=en_US

<http://www.ebay.com/itm/12V-14V-10A-Pulse-Width-Modulation-PWM-DC-Motor-Speed-Control-Switch-/271218590923>

<http://apexmagnets.com/>

http://www.iron-powder.com/Iron_Powder_for_Soft_Magnetic_Products.asp

<http://www.batcap.net/>

<http://www.tapplastics.com/>

<http://wires.co.uk/>

<http://www.maplin.co.uk/>

<http://www.micrometals.com/pcparts/torcore7.html>

<http://store.arduino.cc/ww/index.php>

<http://www.micrometals.com/>

<http://www.technobotsonline.com/bearings/miniature-bearings.html>

<http://www.first4magnets.com/>

<http://www.maxonmotorusa.com/maxon/view/news/MEDIARELEASE-ESCON-ESCON-50-5>

<http://www.goldmine-elec-products.com/contactus.asp>

<http://www.vxb.com/CTUS.html>

<http://www.mcmelectronics.com/product/72-7735>

<http://www.sphere.bc.ca/test/new.html>

<http://www.toolshopusa.com/>

<http://www.indigo.com/magnets/?osCsid=8q4u6im8rksjscoa1vh9i4h7p3#.UqMTOyfnnFw>

<http://www.northwestmagnet.com/permanent-magnets.html>

<http://www.futurlec.com/index.shtml>

<http://www.pittsplas.com/>

<http://www.newark.com/hamlin/55100-3h-02-a/hall-effect-magnetic-magnetic-sensor/dp/50H8225>

<http://www.rmcybernetics.com/shop/pulse-modulator-ocxi>